

Easy14 touch

Easy is an automated kiosk with an innovative design perfect to sell a lot of different products; the dispensing product window is at 90cm from the ground to easily withdraw the products without bending down.

The Easy vending machine is equipped with a robotic product carrier that transports the product from the kiosk's floors to the middle dispensing door without overturn it.

The product is dispensed thanks to the patented dispensing system with separators and **without spirals**, which allows to organize every floor according to the product's size: this system allows the sale of delicate products or products that require horizontal delivery.

Easy14 has **14 lines** on every floor with up to 8 floors.

The kiosk has a 22"HD touch display with 1920x1080 pixel resolution: this screen provides a full products menu with product description, pictures and promotional video.



LOADING SYSTEM MAGEX

The Easy has maximum adaptability to distribute all types of products, with this unique system can be paired more than one lane that will automatically distribute products of different sizes. The system also has interlocking partitions to separate products that are next to one another. This allow complete control of specific lanes so you may dispense products of different sizes.

The Easy also has a self-diagnosis system that will check the operating status of the lane prior to any disbursement of the product.

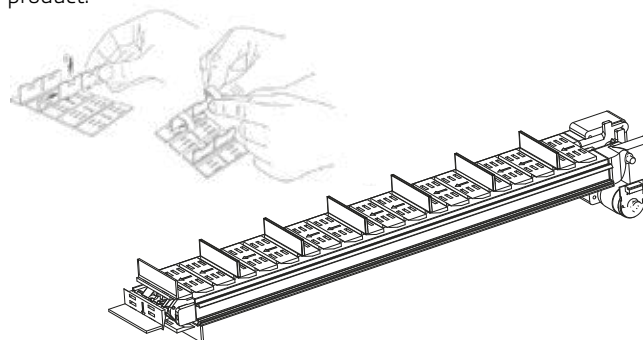

NEW SLIDING PANEL SYSTEM

THE WHOLE STOCK UNIT IS AT YOUR DISPOSAL!

A simple and effective system: a sliding anti-vandal panel closes the floor behind it when the door on the lift opens to deliver the product.

The sliding panel could remain open when the machine is not in the delivery phase to let the customer see all the products inside the machine; it can be also closed to **hide a specific floor with products to be sold only with proof of age**.



Easy14

Easy14 is extendible with
slave modules
with **14 lines** or

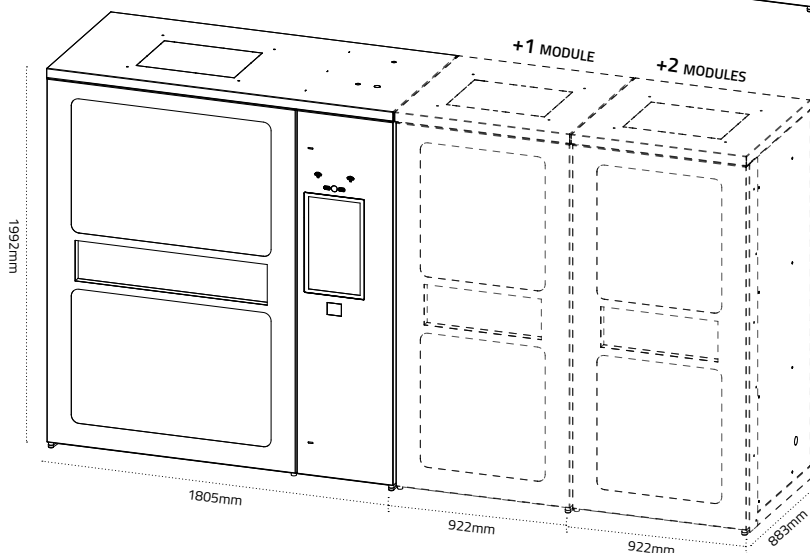
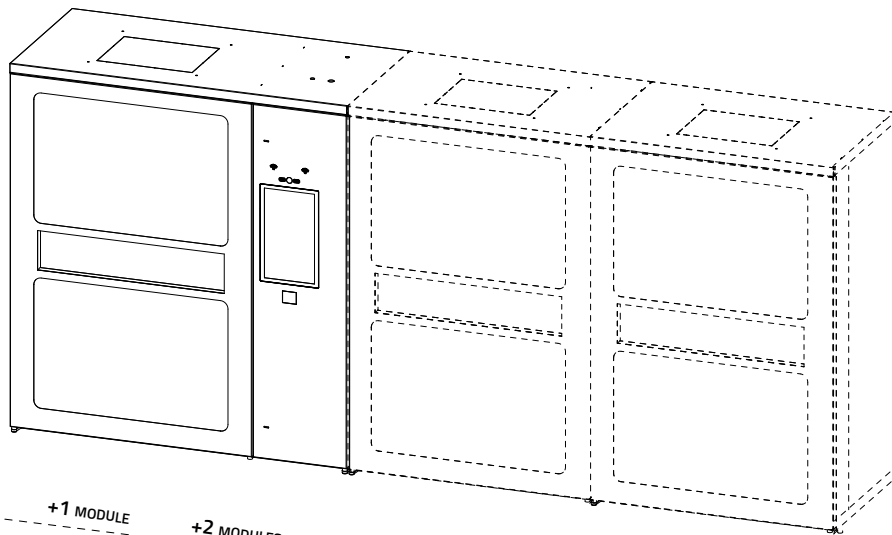

EXTEND IT WITH UP
TO **4** MODULES!

with slave modules with
9 lines

STANDARD COLOURS



White
RAL 9016



Black
RAL 9005

Weight (with 6 floors and cooling system)	610 Kg
Maximum number of floors	8
Selection on every floor	14
Type of lighting	High luminosity LED (30 W)
Voltage supply	100-240 V 50/60 Hz
Internal Temperature	2/4 °C
Power consumption (with cooling unit on)	700 W

TECHNICAL SPECIFICATIONS

- Reinforced retrieval area
- Shatter proof resistant glass
- Console with independent opening
- 22" Monitor with 1920x1080 pixels resolution
- Industrial computer with quad core
- Operating system installed with a SSD 32Gb disc
- LED lighting
- Modular configuration of shelves in height, depth and number of selections
- Console locks isolated
- Self diagnostic system
- Electronic multi-control
- Data management and statistics system
- Temperature control

REAL TIME DATA SERVICE

Magex provides to all its customers a service for the management of the vending machines updated in real time, connected via web and accessible from laptops, mobile phones etc.

This allows you to view real-time data of each sale, the stock status, the coins/banknotes inserted or returned, automatic reboots and other functions. It also monitors the temperature inside the machine with graphics.